

Developers

Gajanana Properties



PARKSTREET - ParkStreet, Opp. Bansal Mall,
Near Amar Shraddha Society - 40 MTR Tarsali Ring Road,
Tarsali, Vadodara.

E : parkstreet03@outlook.com | www.parkspacegroup.com

Call +91 **97262 36561** | **96010 72751**

99044 80003



Architect:

Structure: GALANI STRUCTURES

3d Rendering: PARAM INTERACTIVE



PARKSTREET

4 BHK GRANDIOSE VILLAS

RERA NO. : _____



UNPARALLELED LUXURY AWAITS
AT MARVELLOUS VILLAS



LAYOUT PLAN

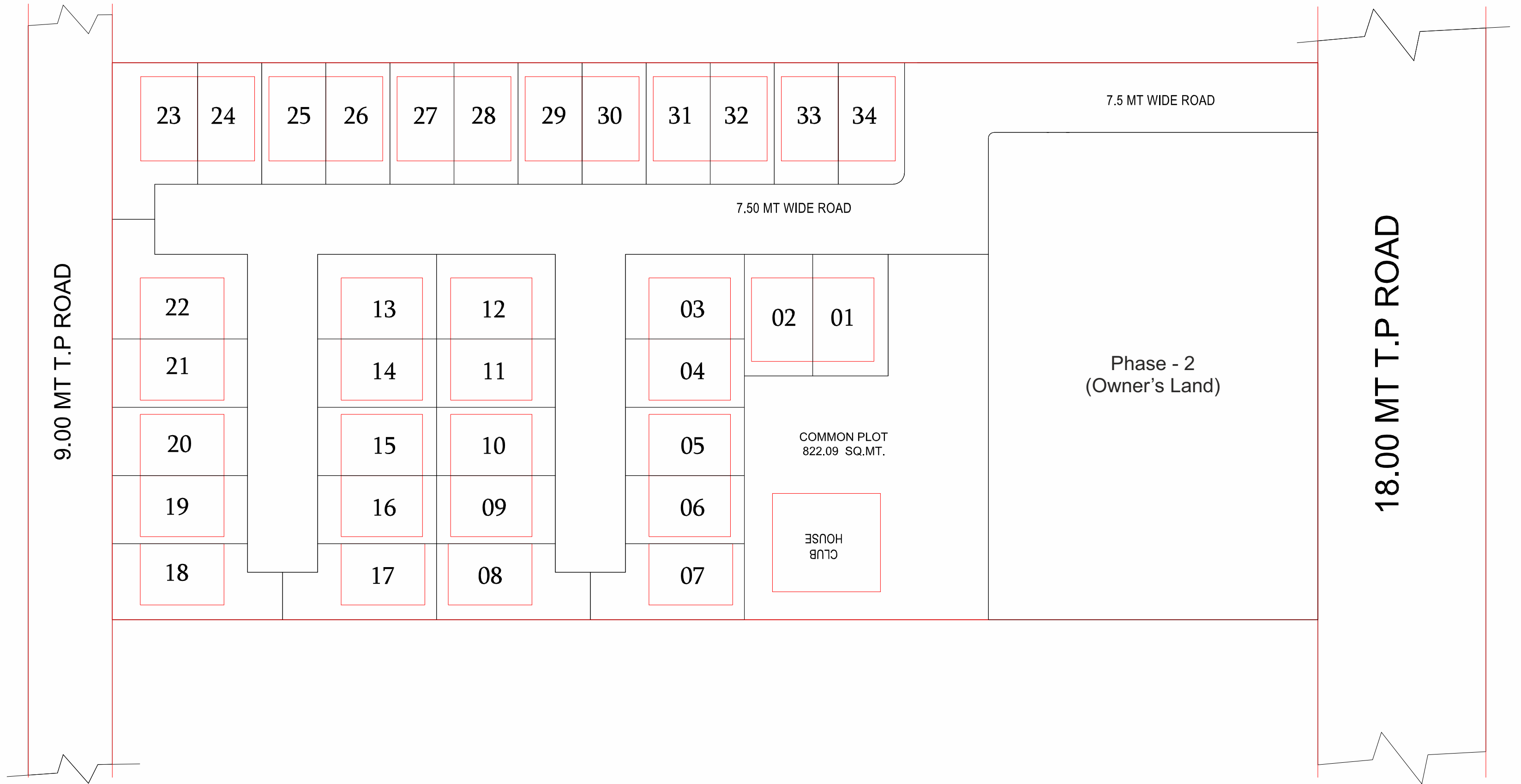



PLOT 1,2,7,8, 17 TO 22

Ground Floor Plan

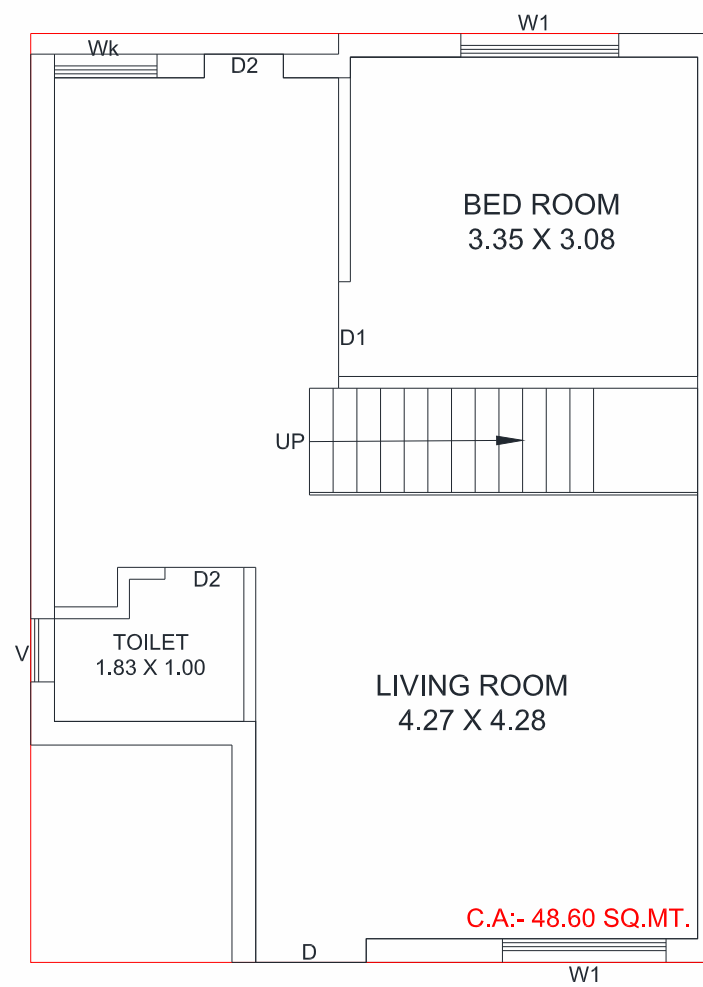

First Floor Plan

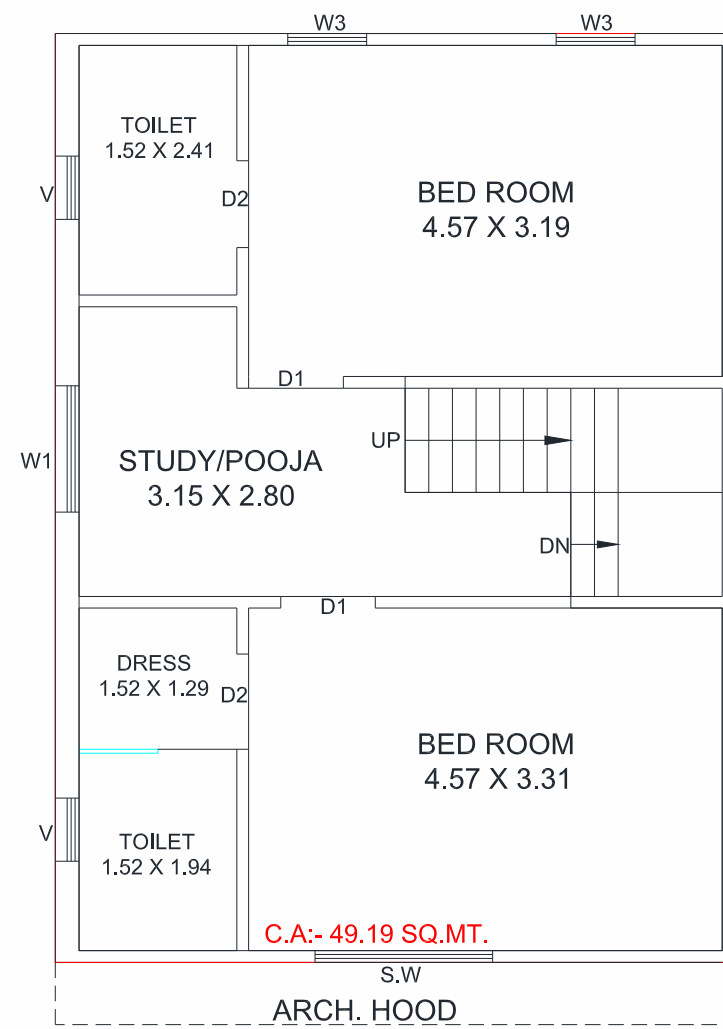

Second Floor Plan

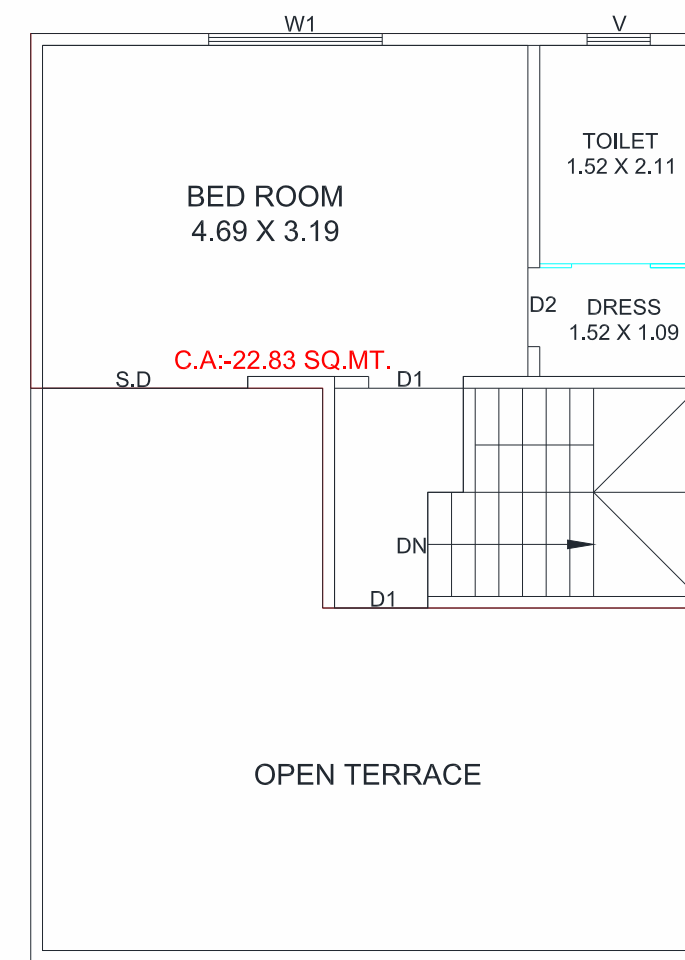

Third Floor Plan

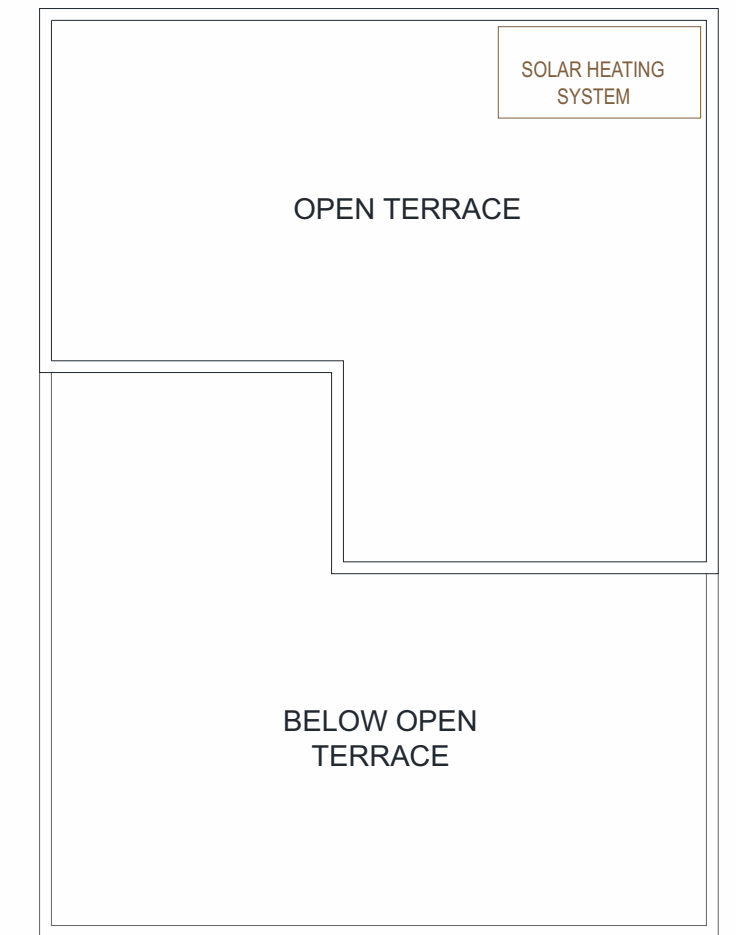



PLOT 3 TO 6, 9 TO 16

Ground Floor Plan

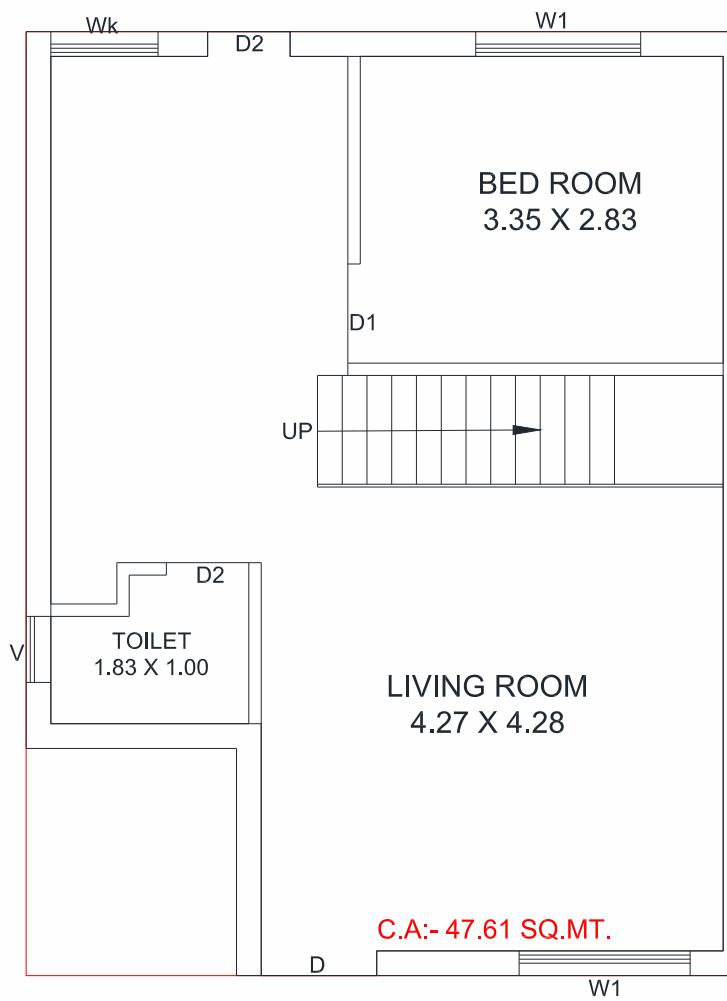

First Floor Plan

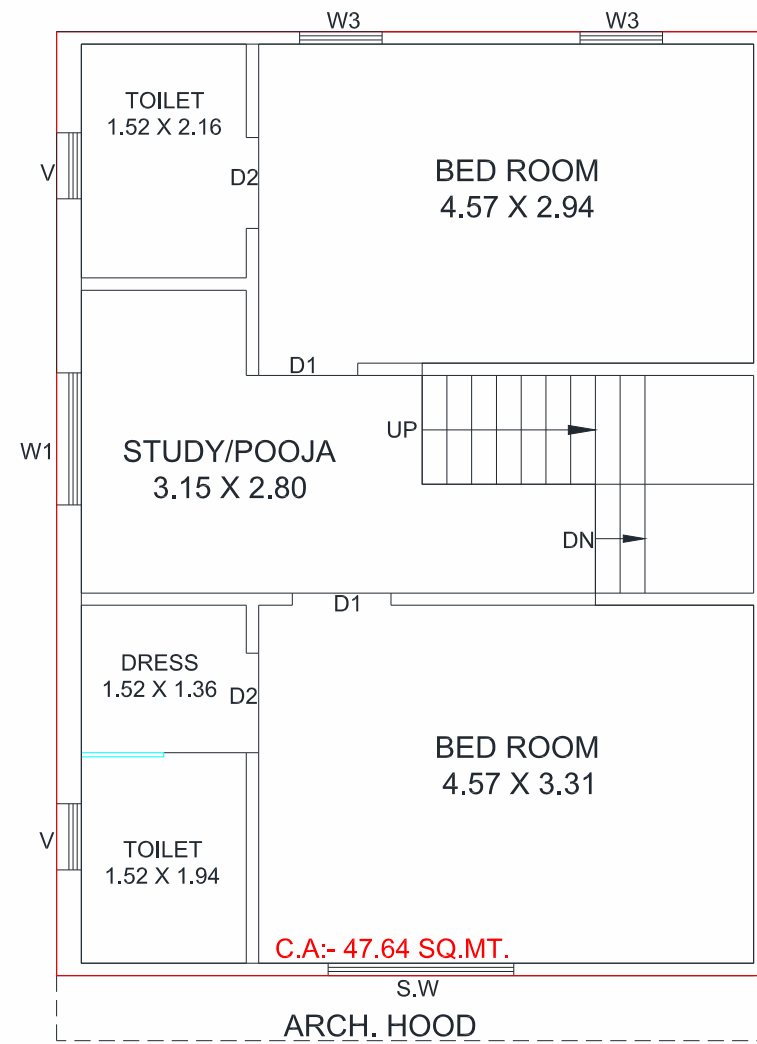

Second Floor Plan

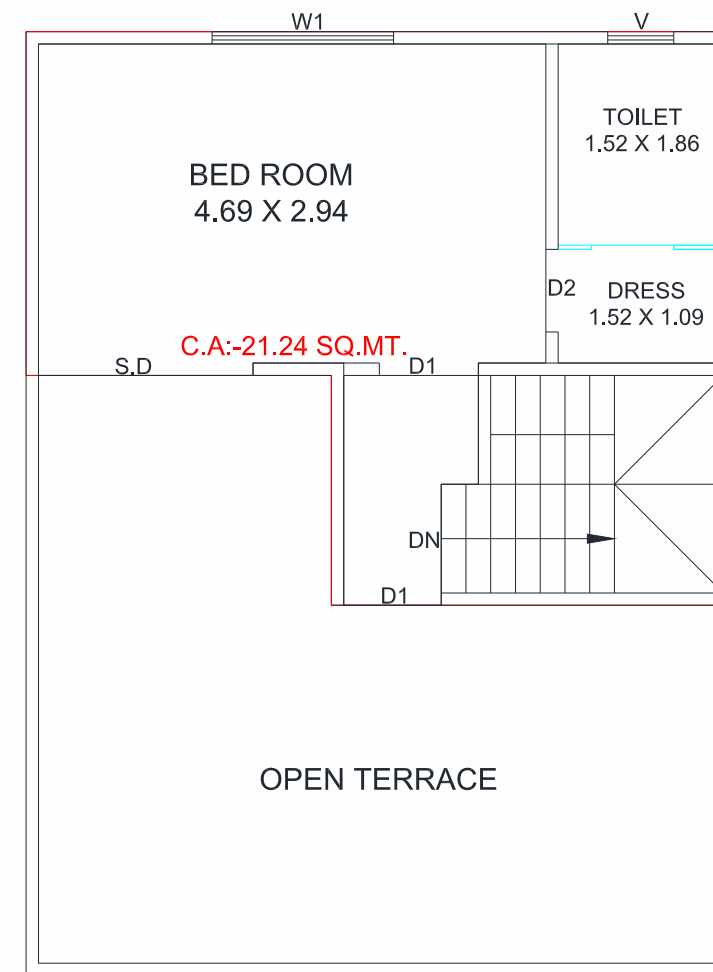

Third Floor Plan

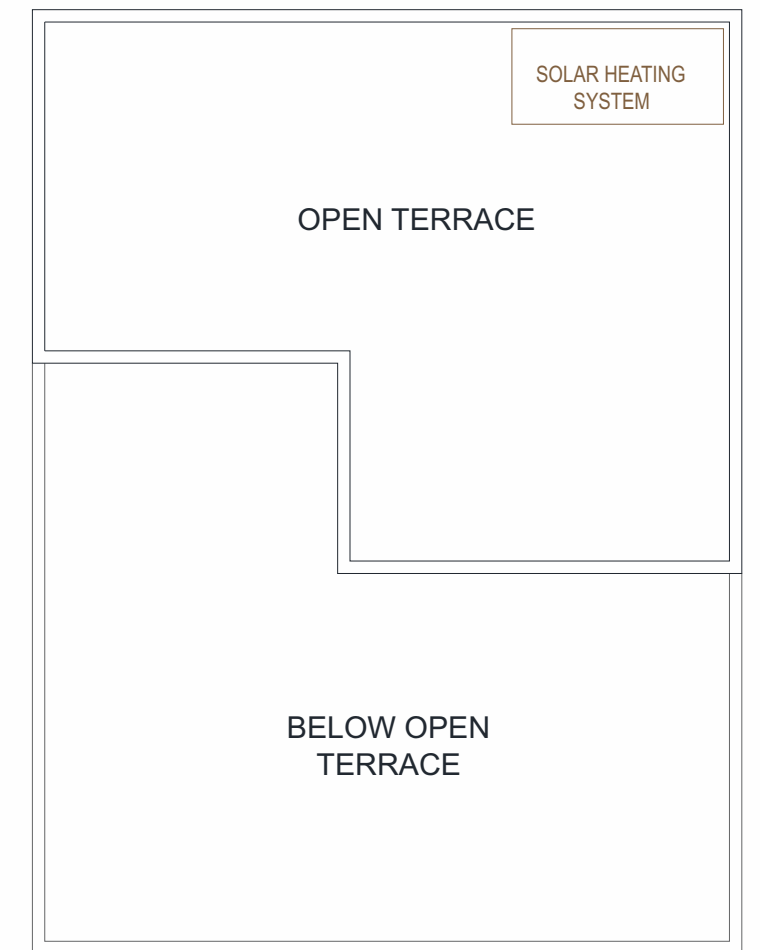



PLOT 23 TO 34

Ground Floor Plan

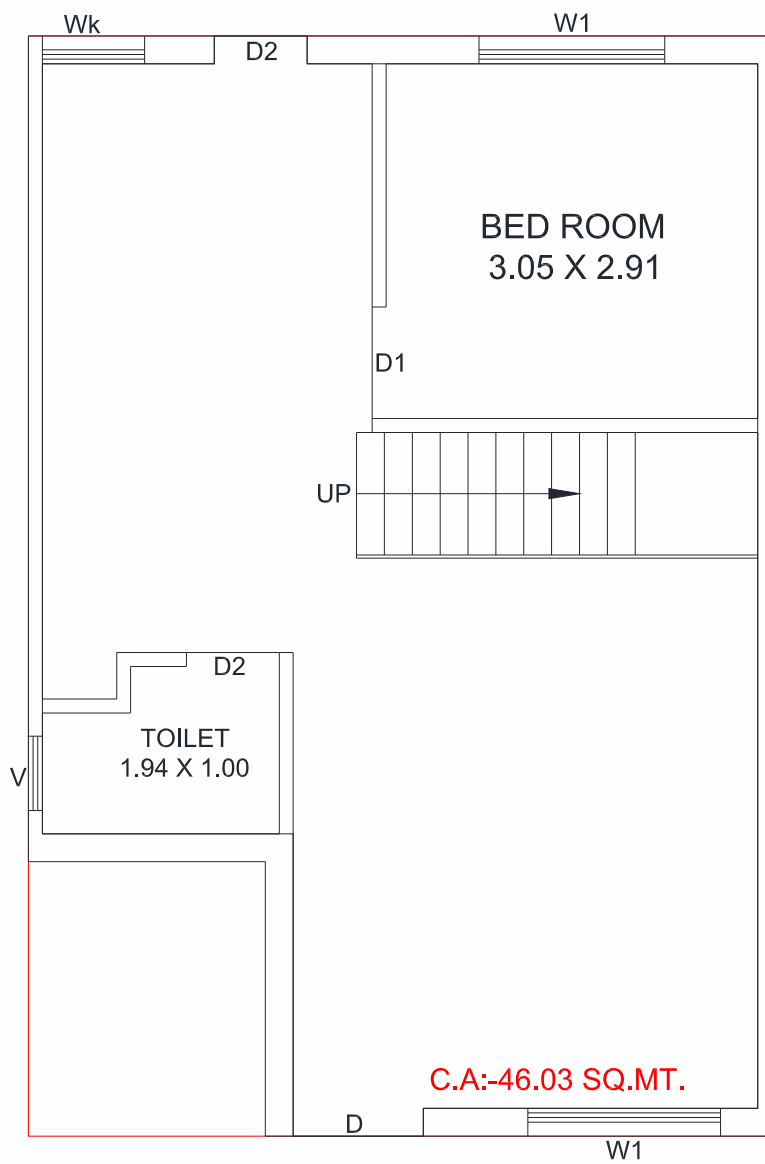

First Floor Plan

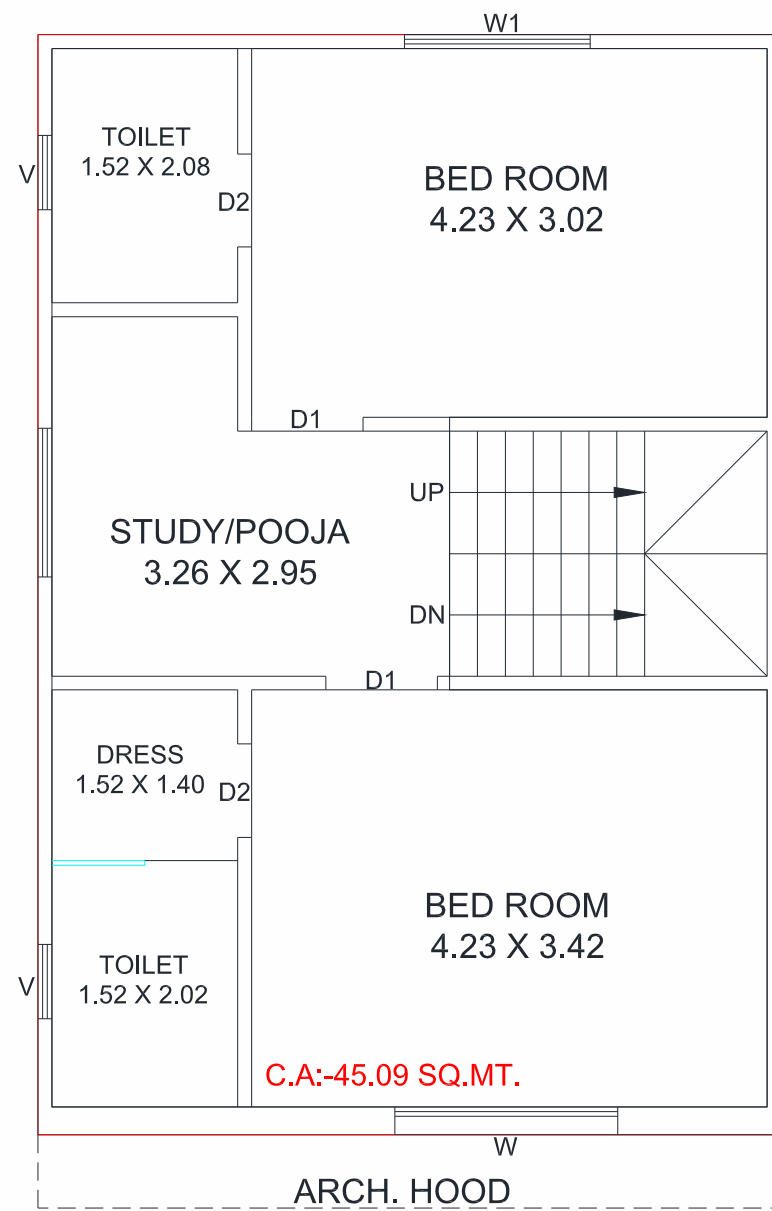

Second Floor Plan

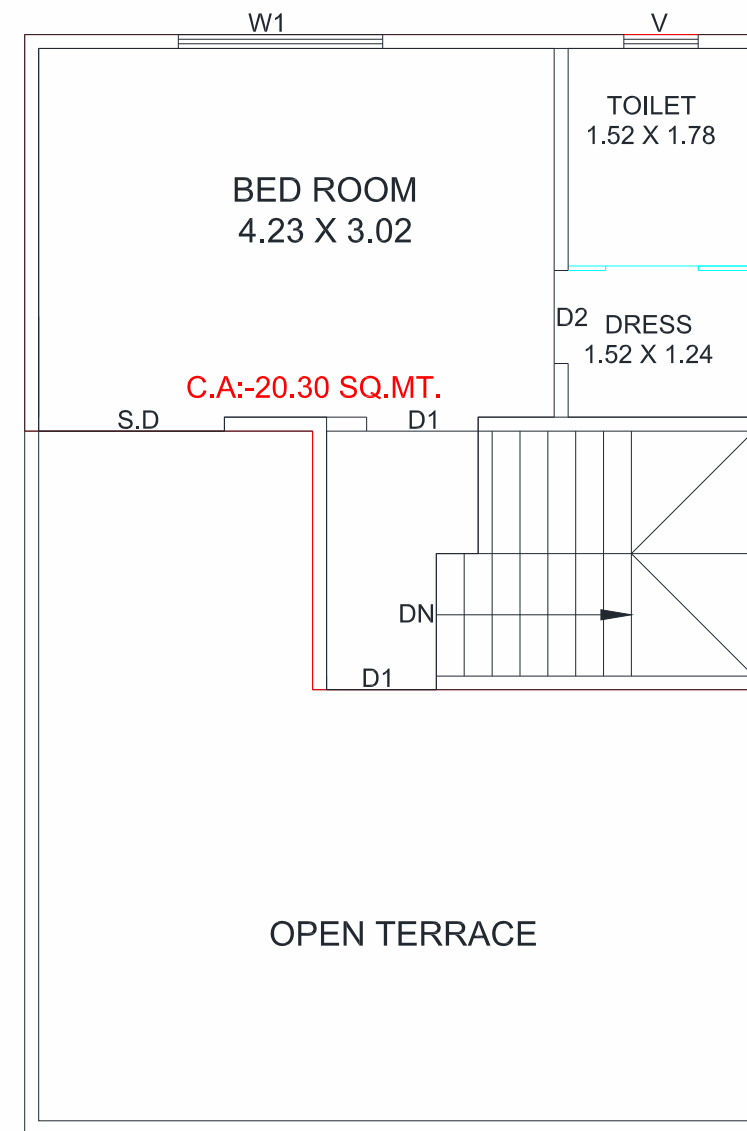

Third Floor Plan

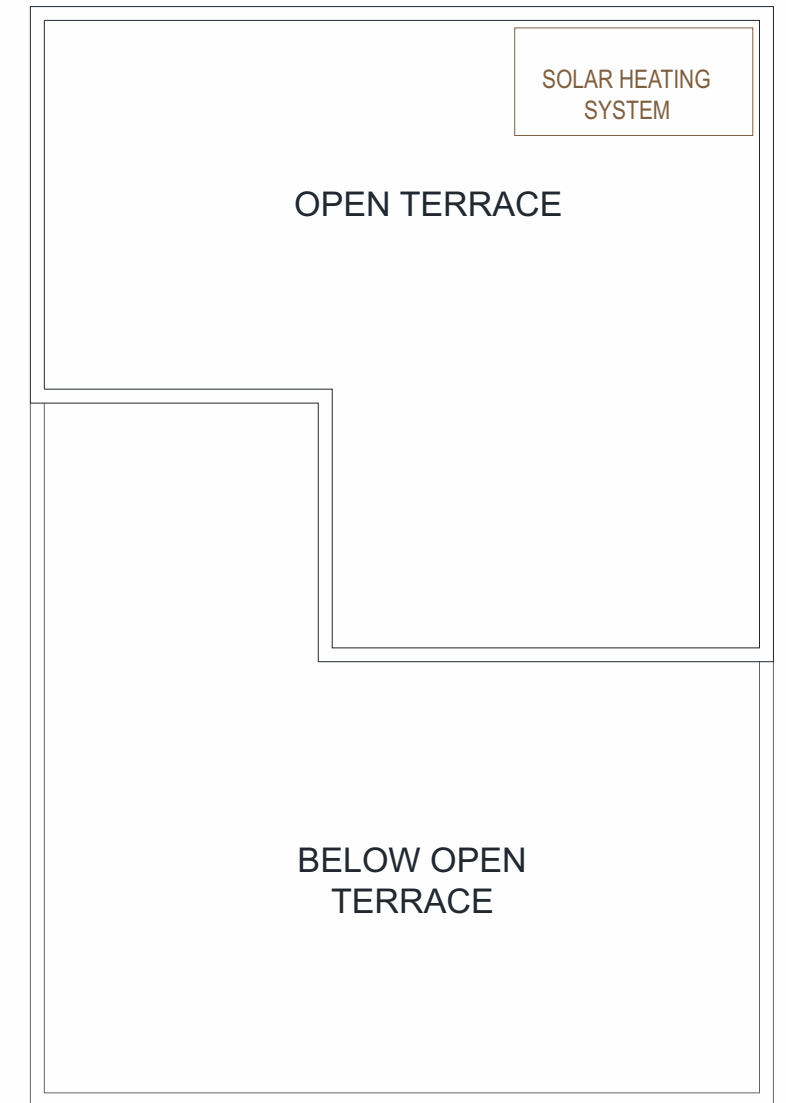

SPECIFICATIONS



RCC STRUCTURE

Earthquake resistant RCC frame structure as per structural engineer's design.



FLOORING

2'7"x8'0" double thickness marble tiles in living room & kitchen. 2x4 High-Gloss Marble Effected Vitrified Tiles in other rooms. Anti-skid Vitrified tiles of reputed make in bathrooms and balconies.



ELECTRIFICATION

Concealed copper wiring of approved quality (Anchor, RR Kabel or equivalent). Branded premium quality modular switches with sufficient electrical point as per architect's plan.



BATHROOMS & TOILETS

Designer bathrooms with Premium Glazed Tiles upto Door level. Premium branded Plumbing fixture (Jaquar, Hindware, Roca or equivalent) and vessels.

AMENITIES



Multipurpose Hall



Children Play Area



Landscape Garden



CCTV Surveillance



KITCHEN

Granite counter with Stainless Steel Sink and tiling upto the door/window level on walls.



PAINT & FINISH

Interiors : Smooth plaster with Wall Putty & Primer
Exterior : Double coat plaster with Water proof and fungal resistant paint. (Asian Paint or equivalent)



TERRACE

Open terrace finished with chemical water proofing and china mosaic flooring/tiles.



DOOR & WINDOWS

Doors : Elegant wooden entrance Door. Internal Flush doors. Windows : Colour anodized / powder coated aluminium section windows with reflective glass of reputed make.

CLUBHOUSE

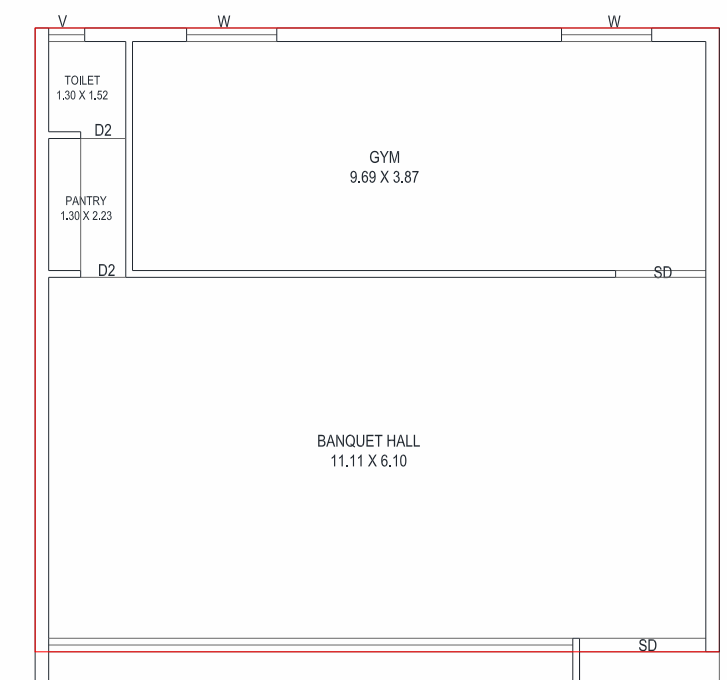

Senior Citizen Deck



AC Gymnasium